

TACO Marine® Leaning Posts

NEPTUNE PREMIUM

L10-1001-1



INSTALLATION INSTRUCTION GUIDE



WARNING:

This product can expose you to chemicals including Di (2-ethylhexyl) Phthalate (DEHP), which is known to the state of California to cause cancer, birth defects or other reproductive harm. For more information, go to www.P65Warnings.ca.gov.

TACO[®]
MARINE

Thank you for purchasing the Neptune Premium Leaning Post by TACO Marine. Since 1959, we have taken great pride in offering the highest-quality products with excellent customer service. We stand behind our products 100 percent. Please visit our website tacomarine.com for more detailed information on a wide variety of products and to register your new accessory for warranty.

Kit Contents

REFER TO FIGURE 1

| ITEM | QTY | DESCRIPTION |
|------|-----|---|
| A | 1 | Seat Cushion |
| B | 1 | Fiberglass Tray |
| C | 2 | Fiberglass Deck with Rod Holders |
| D | 1 | Aluminum Port Leg |
| E | 2 | Aluminum Starboard Leg |
| F | 4 | Aluminum Crossboard |
| G | 1 | Aluminum Seat Hinge |
| H | 4 | Aluminum Footrest |
| I | 1 | Nylon Washer |
| J | 1 | Socket Head Cap Screw, 5/16" x 18 x 1-1/4"L |
| K | 16 | Flat Head Screw, 1/4" x 20 x 3/4"L |
| L | 4 | Lanyard Stay |
| M | 16 | Flat Head Screw, #8 x 1/2"L |
| N | 4 | Wood Screw, #12 x 1-1/4"L |
| O | 12 | Cooler Strap and Brackets |
| P | 16 | Button Head Screw, 5/16" x 1-1/4"L |
| Q | 2 | Silicone Washer, 1-1/2" |

Required*

*not included

- PHILLIPS HEAD SCREWDRIVER OR SCREW GUN
- ADJUSTABLE WRENCH
- WAX AND LEAD PENCIL
- DRILL
- JIG SAW
- MARINE-GRADE SEALANT
- 24" X 54" MARINE LUMBER

L10-10003

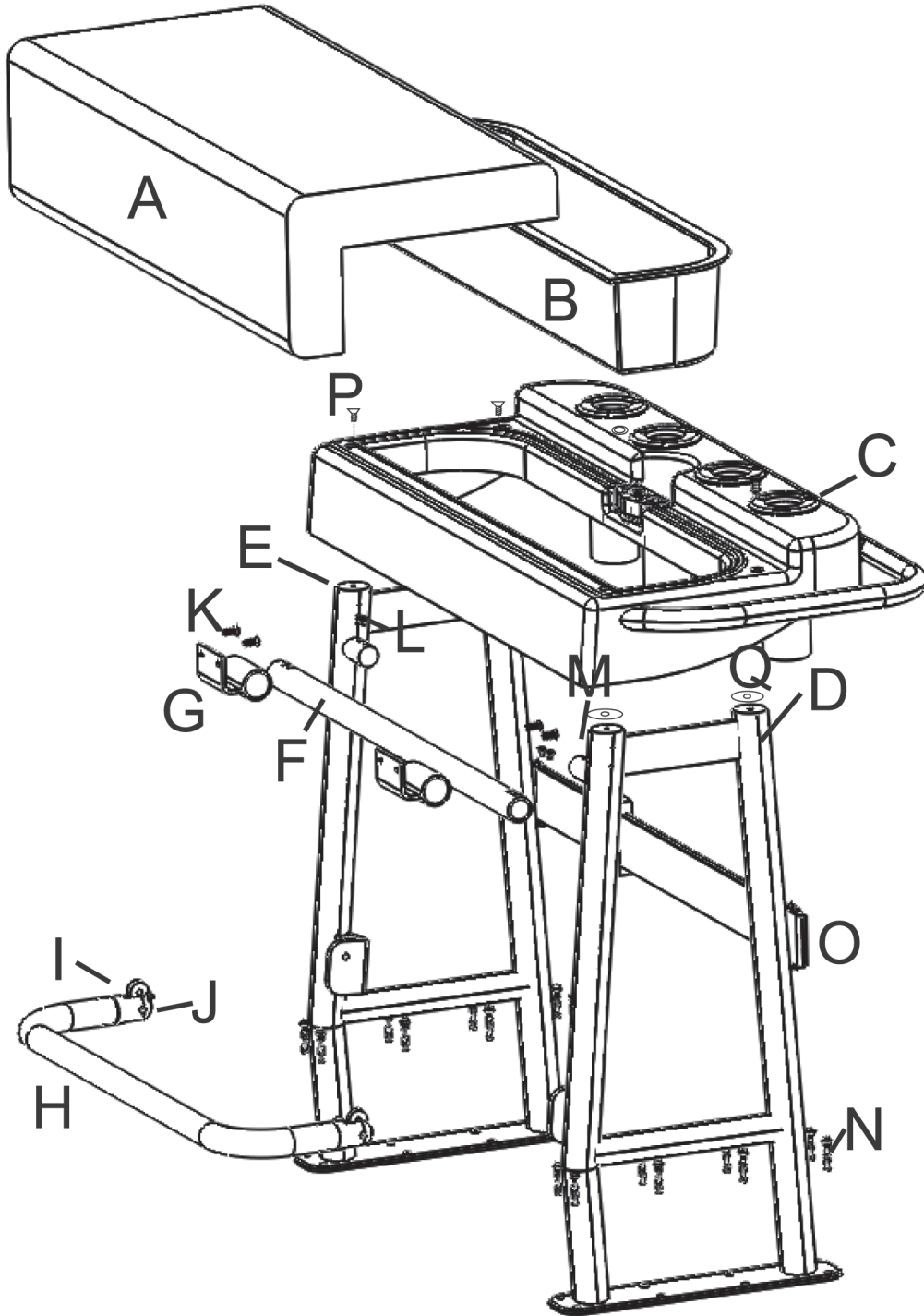

ASSEMBLY INSTALLATION

REFER TO FIGURE 1 (P. 3)

Clean any dirt or packing debris from accessory splines.

WARNING

- It is very important that the leaning post is firmly attached to the deck to prevent injury. Consult your marine professional for recommendation on proper backing plates and thru-bolting for solid installation.
- Be sure not to drill through wiring, fuel tank or hoses.

1. Slide the 2 seat hinges (G) onto the cross bar (F) with the hinges facing as shown on the assembly diagram.
2. Temporarily slide the hinges to the center of the bar, as you will need to get to the screw holes at the end of the cross bar (F)
3. Position the Port and starboard legs (D,E) as in the illustration.
4. Place the crossbar with hinges over the studs on the legs and secure using screws (M)
5. 5. Install footrest (H) onto the legs using screw (J) and placing Nylon washers (I) one on each side of the clevis.
6. Install Fiberglass Deck (C) to the top of the legs using screws (P) Place Washer (Q) between leg and deck (C).
7. Slide the hinges outboard so that the butt against the legs. Position the cushion (A) over the deck and secure to the hinges using screws (K).
NOTE: The threaded holes in the cushion are obscured with the seat material. Use a sharp object to puncture the material to allow the screw to thread into the T-Nut in the cushion.
8. The lanyard that is attached to the seat is fastened to the leg using the lanyard stay (L) and screws provided.
9. The Cooler strap (O) is attached to the back of the legs, using hardware provided.
10. Install the fiberglass tray (B) into the fiberglass deck. Your kit includes several Velcro pads which can be installed between the fiberglass deck and the fiberglass tray.

RECOMENDED IF ADDED

SECURING IS REQUIRED

1. Before assembling the Leaning Post, check the footprint dimensions and mark the approximate locations of the mounting holes with a wax pencil.
2. Check underneath the deck to make sure that any gas tanks, gas lines, electrical wires, etc. are far enough below the deck so they will not be damaged when drilling or through bolting the Leaning Post to the deck.
CAUTION! If you do not know what is directly underneath your mounting location, ask your boat manufacturer, a qualified boat mechanic or use a flashlight to view the area through an existing access hole or make a hole in an area that you can properly seal and cover afterwards.
3. Assemble the Leaning Post according to the assembly instructions provided.
4. Using the footprint of your Leaning Post, make backing plates out of a piece of 1/2" marine lumber or 1/4" aluminum. Make sure you leave enough material for a cover plate (Step 14).
5. If the area underneath is acceptable, place the Leaning Post in the desired location, about 12" from the console.
6. Make sure that your Leaning Post is straight and parallel with your console, centered positioning.
7. Mark the hole locations through the mounting holes in each mounting flange, making sure that the Leaning Post does not move.
8. Install a 3/16" drill bit into your drill and put a piece of tape on the drill bit 1" from the tip so you will know when to stop and do not drill too deep.
9. Drill the mounting holes.
10. Put the Leaning Post back in place to make sure that all the holes line up. Enlarge holes if necessary. Use marine sealant on bottom of mounting plates and fastener holes for a good seal.
11. If you do not have an access hatch to the underside of the deck, you will have to cut an access hole between the two mounting locations on each side of the leaning post big enough so you can reach inside and install a backing plate and locknuts or T-nuts on the mounting screws. Make sure that the access hole is completely within the mounting feet of the leaning post so that you can seal and cover it up with a piece of Marine Lumber after the installation.
12. Put sealant on the threads of each of the 1/4" mounting bolts and insert them into the holes.
13. Install the backing plates and locknuts or T-nuts on the mounting bolts through the access holes and tighten them securely.
14. Using a piece of 24" x 54" marine lumber or 1/8" aluminum, cut the cover plate to fit within the footprint of your Leaning Post.
15. Drill clearance holes in the marine lumber or aluminum plate for the mounting screws.
16. Using the clearance holes mark the deck and drill pilot holes so the screws can thread into the deck.
17. Place sealant around each of the access holes and line up the holes in the cover plate with the pilot holes, put sealant on the screw threads and install the screw to secure the cover plate to the deck.
18. Install the optional cooler and adjust the straps.

How to clean

Always use a mild, non-abrasive soap and fresh water. Thoroughly wash the aluminum and vinyl material with a soft towel or sponge to remove dried salt crystals and other contaminants. Rinse completely with fresh water.

Safe Cleaners

Mild dish washing liquid, specialty marine cleaners:

Sea Safe Boat Wash, Boat Wash Concentrate and Super Suds.

Safe marine lubricants:

CRC Corrosion Inhibitor, Corrosion Block and Get Some Extreme.

Harmful Cleaners

Bleach (Clorox, etc.) and mild abrasive cleaners:

Ajax, Comet, Soft Scrub, Rubbing Compounds, etc.

Strong cleaners:

409, Engine Degreasers, etc.

Acids of any type:

Such as, Muriatic or aluminum acid

Need Support?

Contact Us



1.800.653.8568



support@tacomarine.com



tacomarine.com



50 NE 179th ST
Miami, FL. 33162



@tacomarine



@taco_marine

TACO Marine[®]

TACO[®]

MARINE

INSTRUCTIONS-LEAN/POST